

AQUAGEM®

INVERTER POOL PUMP

INSTALLATION AND OPERATION MANUAL



CONTENTS

1. ⚠ IMPORTANT SAFETY INSTRUCTIONS	1
2. TECHNICAL SPECIFICATIONS	2
3. OVERALL DIMENSION (mm)	2
4. INSTALLATION	3
5. SETTING AND OPERATION	5
6. WIFI OPERATION	14
7. EXTERNAL CONTROL	22
8. PROTECTION AND FAILURE	24
9. MAINTENANCE	28
10. WARRANTY & EXCLUSIONS	28
11. DISPOSAL	28

THANK YOU FOR PURCHASING OUR INVERTER POOL PUMPS.

THIS MANUAL CONTAINS IMPORTANT INFORMATION THAT WILL HELP YOU IN OPERATING AND MAINTAINING THIS PRODUCT.

PLEASE READ THE MANUAL CAREFULLY BEFORE INSTALLATION & OPERATION AND RETAIN IT FOR FUTURE REFERENCE.



1. IMPORTANT SAFETY INSTRUCTIONS

This guide provides installation and operation instructions for this pump. If you have any other questions about this equipment, please consult your supplier.

1.1 When installing and using this electrical equipment, basic safety precautions should always be followed, including the following:

- RISK OF ELECTRICAL SHOCK. Connect only to a branch circuit protected by a ground-fault circuit interrupter (GFCI). Contact a professionally trained and qualified electrician if you cannot verify that the circuit is protected by a GFCI.
- TO PREVENT THE ELECTRICAL SHOCK RISK, please connect the ground wire on the motor (green/yellow) to the grounding system.
- This pump is for use with permanently installed in-ground or above-ground swimming pools and may also be used with hot tubs and spas with a water temperature under 50°C. Due to the fixed installation method, this pump is not suggested to be used on above-ground pools that can be readily disassembled for storage.
- The pump is not submersible.
- Never open the inside of the drive motor enclosure.

1.2 All installations must be fitted with earth leakage or residual current protection devices, having a rated residual operating current not exceeding 30mA.

WARNING:

- Fill the pump with water before starting. Do not run the pump dry. In case of dry run, mechanical seal will be damaged and the pump will start leaking.
- Before servicing the pump, switch power OFF to the pump by disconnecting the main circuit to the pump and release all pressure from pump and piping system.
- Never tighten or loosen screws while the pump is operating.
- Ensure that the inlet and outlet of the pump are unblocked with foreign matter.

2. TECHNICAL SPECIFICATIONS

Model	Advised Pool Volume (m ³)	P1	Voltage (V/Hz)	Qmax (m ³ /h)	Hmax (m)	Circulation (m ³ /h)	
		KW				At 10m	At 8m
IH20	30-50	0.80	220-240/ 50/60	24.2	18.0	14.4	18.5
IH24	40-70	1.05		26.0	20.0	19.3	23.0
IH30	60-90	1.40		28.3	20.5	24.5	27.6
IH40	80-120	1.75		40.3	20.5	32.0	35.6

3. OVERALL DIMENSION (mm)

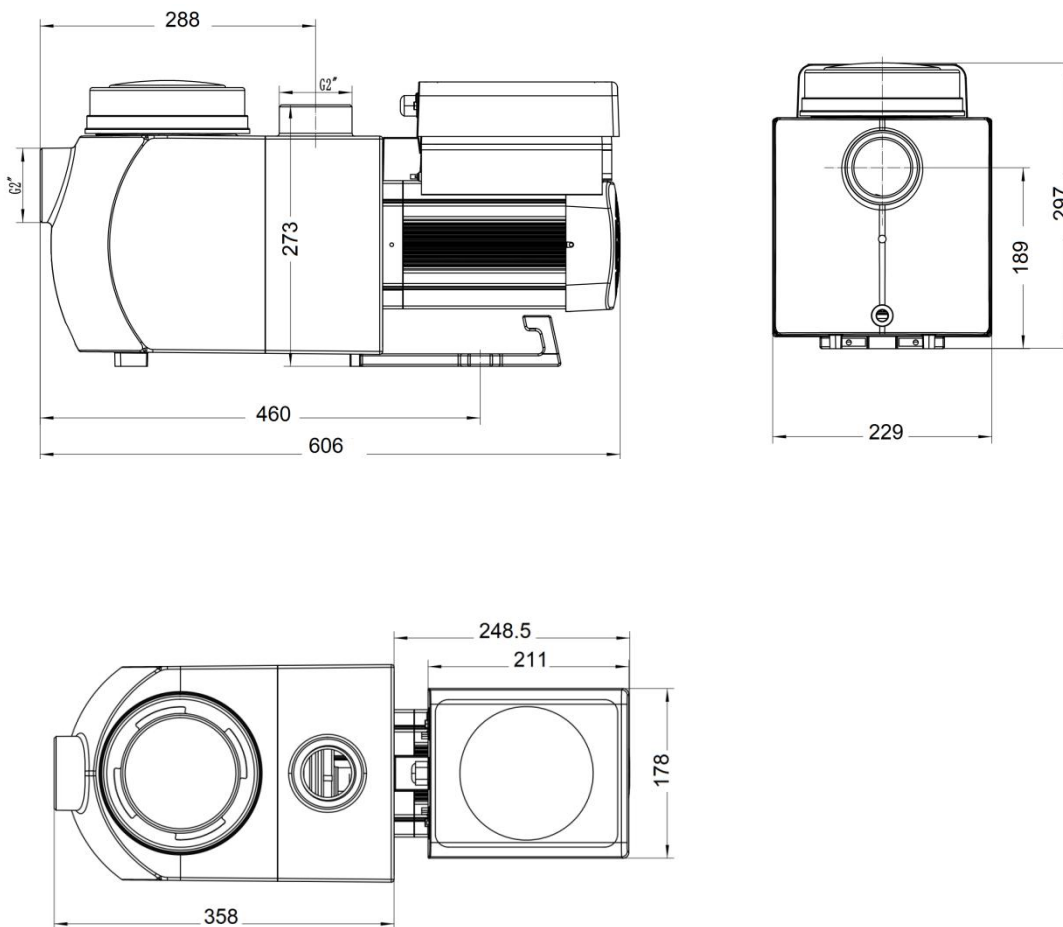

Figure 1 - Pump Dimensions

4. INSTALLATION

4.1. Pump Location

- 1) Install the pump as close to the pool as possible, to reduce friction loss and improve efficiency, use short, direct suction and return piping.
- 2) To avoid direct sunshine, heat or rain, it is recommended to place the pump indoors or in the shade.
- 3) DO NOT install the pump in a damp or non-ventilated location. Keep pump and motor at least 150mm away from obstacles, pump motors require free circulation of air for cooling.
- 4) The pump should be installed horizontally and fixed in the hole on the support with screws to prevent unnecessary noise and vibration.

4.2. Plumbing and Valves

- 1) The pump inlet/outlet union size: optional with 48.5/50/60.3/63mm.
- 2) For optimization of the pool plumbing, a larger pipe size should be used. It is recommended to use a pipe with size of 63mm.
- 3) When installing the inlet and outlet fittings (joints) with the plumbing, use the special sealant for PVC material.
- 4) The dimension of suction line should be the same or larger than the inlet line diameter, to avoid pump sucking air, which will affect the pump's efficiency.
- 5) To reduce friction loss and improve efficiency, plumbing on the suction and return side should be short and direct.
- 6) Flooded suction systems should have valves installed in both the pump suction and return line, which is convenient for routine maintenance. A valve, elbow, or tee installed on the suction line should be no closer to the front of the pump than seven times the suction line diameter.
- 7) Use a check valve in the return line where there is a significant height between the return line and the outlet of the pump, to prevent the pump from the impact of medium recirculation and pump-stopping water hammer.

4.3. Fittings

- 1) Elbows should be no closer than 350mm to the inlet. Do not install 90° elbows directly into the pump inlet/outlet. Joints must be tight.
- 2) Joints must be tight.

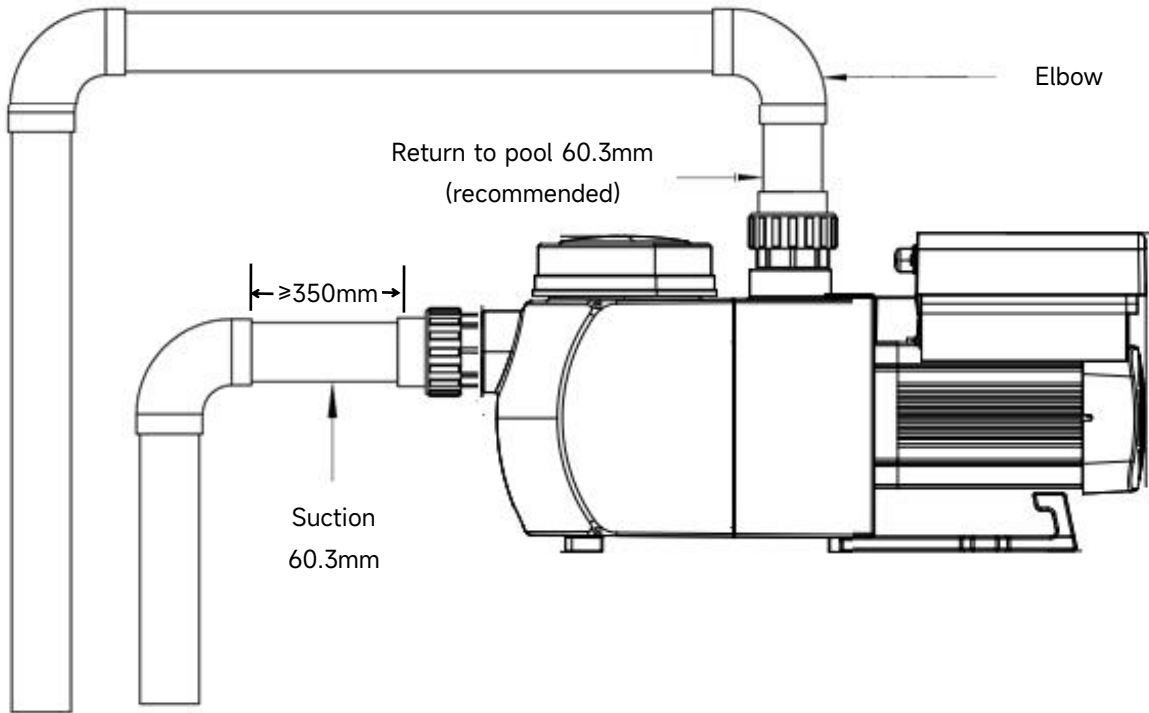

Figure 2 - Plumbing and Fittings installations

* The pump inlet/outlet union size: optional with 48.5/50/60.3/63mm

- 3) Use the UNION KIT supplied by the pump manufacturer (Refer to Figure 3). Do not use other fittings to connect the pump inlet/outlet, in case the fittings are not match and damage the pump body.

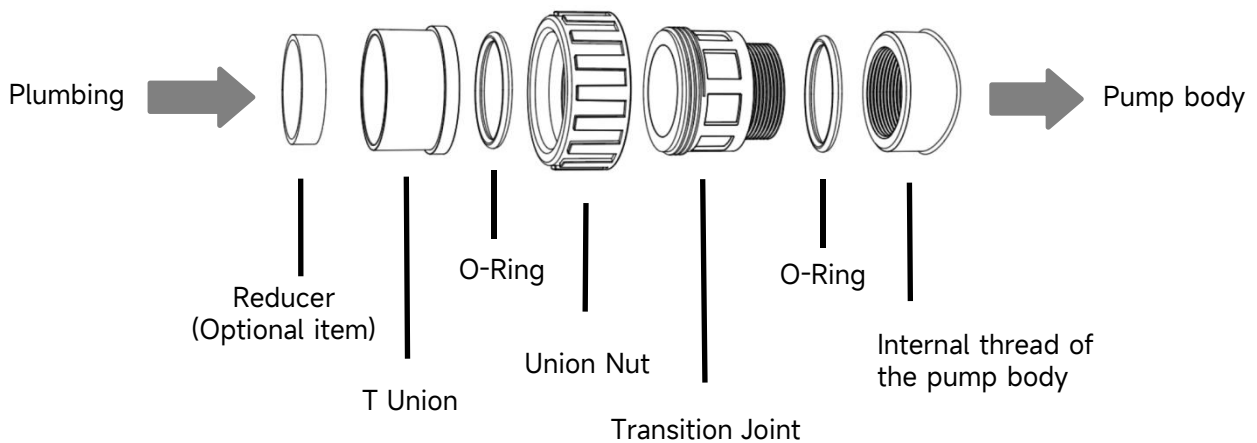

Figure 3 - Union Kit

4.4. Check before initial startup

- 1) Check whether pump shaft rotates freely;
- 2) Check whether power supply voltage and frequency conform to the nameplate;
- 3) Facing the fan blade, the direction of motor rotation should be clockwise;
- 4) It is forbidden to run the pump without water.

4.5. Application conditions

Ambient temperature	Indoor installation, temperature range: -10 - 42°C
Water temperature	5°C-50°C
Salt water available	Salt concentration up to 3.5%, i.e 35g/l
Humidity	≤90% RH, (20°C±2°C)
Installation	The pump can be installed max. 2m above water level;
Protection	Class F, IP55

5. SETTING AND OPERATION

5.1. Display on control panel

	① Power consumption
	② Running capacity / Flow rate
	③ WIFI indicator
	④ Unit of flow
	⑤ Timer period
	⑥ Timer 1/2/3/4
	Backwash/unlock
	Up/down: to change the value (capacity/flow/time)
	Switch between Manual Inverter Mode and Auto Inverter Mode Manual Inverter Mode: The running capacity will be set manually between 30%-120% Auto Inverter Mode: The running capacity will be automatically adjusted between 30%-120% according to the preset flow rate. The default mode is Manual Inverter mode.
	Timer setting



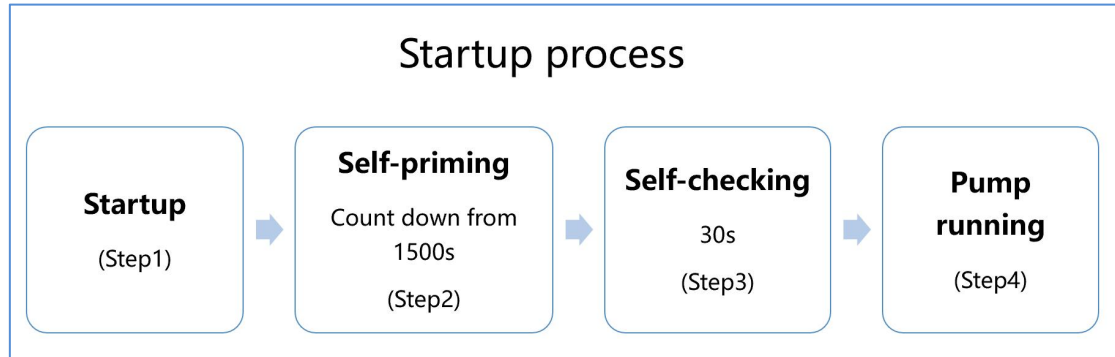

On/off

5.2. Startup process overview



① Step 1: Startup

- Press and hold  for more than 3 seconds to unlock the screen.
- Press  to startup the pump.

② Step 2: Self-priming

- The pump will start counting down from 1500s; When the system detects the pump is full of water, it will stop counting down and exit priming automatically.
- Users can exit self-priming manually by pressing  for more than 3 seconds. It's recommended that users should make sure the pump is full of water before exiting self-priming process;
- Users can enter the parameter setting to disable the default self-priming function (see 5.11).



③ Step 3: Self-checking

- The pump will recheck for 30s again to make sure the self-priming (Step2) is completed.

④ Step 4: Pump running

- The pump will run at 80% of the running capacity at the initial startup after the self-priming.

5.3. Startup

When the power is switched on, the screen will fully light up for 3 seconds, the device code will be displayed, and then it will enter the normal working state. When the screen is locked, only the button  will light up; Press and hold  for more than 3 seconds to unlock the screen. The screen will automatically lock up when there is no operation for more than 1 minute and the brightness of the screen will be reduced to 1/3 of the normal display. Short press  to wake up the screen and observe the relevant operating parameters.



5.4. Self-priming

Each time the pump is started, it will start self-priming.

When the pump performs self-priming, it will count down start from 1500s and stop count down automatically when the system detects the pump is full of water, then the system will recheck for 30s again to make sure the self-priming is completed.



Users can exit self-priming manually by pressing  for more than 3 seconds. The pump will enter the default Manual Inverter mode at the initial startup.

Remark:

- 1) The pump is delivered with self-priming enabled. Each time the pump restarts, it will perform self-priming automatically. Users can enter the parameter setting to disable the default self-priming function (see 5.11)
- 2) If the default self-priming function is disabled, and the pump has not been used for a long time, the water level in the strainer basket may drop. Users can manually activate the self-priming function by pressing both   for 3 seconds, the adjustable period is from 600s to 1500s (default value is 600s).
- 3) After the manual self-priming is completed, the pump will return to the previous state before activating the manual self-priming. If the pump has entered the Auto Inverter mode previously, the pump will perform self-learning for 180s to redefine the adjustable flow range after the manual self-priming.
- 4) Users can press  for more than 3 seconds to exit the manual self-priming, and the pump will run the same as the manual self-priming is completed.

5.5. Backwash











Users can start the backwash or fast re-circulation in any running state by pressing .

	Default	Setting range
Time	180s	Press  or  to adjust from 0 to 1500s with 30 seconds for each step
Running capacity	100%	80-100%, enter the parameter setting (see 5.11)

Exit backwash:

When backwash mode is on, users can hold  for 3 seconds to exit, the pump will return to the previous state before backwash. If a speed limit is set by the users, the running capacity of the backwash will not exceed the set speed limit. (see 5.10)

5.6. Manual Inverter Mode













1		Hold  for more than 3 seconds to unlock the screen.
2		Press  to start. The pump will run at 80% of the running capacity at the initial startup after the self-priming.
3	 	Press  or  to set the running capacity between 30%-120%, each step by 5%.
4		Press  again to switch to Auto Inverter mode.

Note:

- 1) When the pipeline pressure is too high, to maintain an adequate flow rate, users can set the running capacity to 105%-120%. The pump will run at a higher speed but will not exceed the rated power of each model.
- 2) If the pump has reached the rated power at 105% and the users continues to increase the running capacity, the display will return to 105% when the motor speed is stabilized.

5.7. Auto Inverter Mode

Under Auto Inverter Mode, the pump can automatically detect the system pressure and adjust the speed of motor to reach the set flow.

1		Unlock the screen, press  to switch from the Manual Inverter mode to Auto Inverter mode.
2	 	The flow rate could be adjusted, by pressing  or  with 1m ³ /h for each step.
3	 	The unit of flow rate could be changed to LPM, IMP GPM or US GPM, by pressing both   for 3 seconds.
4		Press  to switch to Manual Inverter mode.

Self-learning:

When first switching to the Auto Inverter mode, the system will perform the self-priming process (see 5.4) and then the self-learning process for 180s and redefine the adjustable flow range of the pump by detecting the pipeline pressure.

eg: the default adjustable flow range of InverHero IH24 is 5-25 m³/h, after self-learning, the range may be redefined to 7-22 m³/h. If the set flow is beyond the current adjustable range, the actual achievable flow rate will be displayed after the motor speed is stabilized.

The default adjustable flow range for InverHero is as below:











Model	Default adjustable flow rate range
IH20	5-20 m ³ /h
IH24	5-25 m ³ /h
IH30	5-30 m ³ /h
IH40	8-35 m ³ /h

Note:

- 1) After the first self-priming, the pump will redefine the adjustable flow range. The pipeline pressure will be recorded by the system after the pump runs at the set flow/capacity for 5 minutes without other operations.
- 2) During the pump running, if it is detected that the pipeline pressure changes beyond a certain range, the icon of % or m³/h (or other flow units) symbol will flash for 5 minutes. If the change lasts for 5 minutes, the pump will perform a self-priming and self-learning process, and redefine the flow range accordingly.
- 3) After the redefinition of the flow range, the pump will automatically adjust the running capacity to reach the set flow.
- 4) Users can set the time interval to trigger the self-learning automatically in the parameter setting (see 5.11) to ensure the accuracy of the flow rate.



5.8. Timer mode

The pump's on/off and running capacity could be commanded by a timer, which could be programmed daily as needed.

1	Enter timer setting by pressing 
2	Press  or  to set the local time.
3	Press  to confirm and move to time-1 setting.
4	Press  or  to choose the desired running periods, running capacity or flow rate (when % icon is flashing, users can change to set the flow rate by pressing ).
5	 Repeat above steps to set the other 3 timers.
6	 Hold 3 seconds to save setting and activate timer mode.
7	 or  Check 4 timers to make sure there is no invalid setting.

Note:







1) When timer mode is activated, if the set time period contains the current time, the pump will start running according to the set running capacity or flow rate. If the set time period does not contain the current time, the timer number 1 2 3 4 (1 or 2 or 3 or 4) that is about to start running will be displayed on the controller and flash, **00:00 - 00:00** will display the corresponding time period, indicating a successful timer setting.

2) During timer setting, if you want to return to the previous setting, hold both   for 3 seconds. If you don't need to set all 4 timers, you can hold  for 3 seconds, the system will automatically save the current set value and activate the timer mode.

3) Users can exit the timer mode by pressing .

5.9. Skimmer Mode

The skimmer mode enables the pump to skim the water surface, prevents the debris from accumulating, and provides users with a cleaner pool.

Hold  and  to enter the preset interface of the skimmer mode, press  or  to view the 3 presets, the selected preset will be activated after 8s without operation. Users can exit the skimmer mode without activating it by holding  and  in the preset interface.

At the skimmer duration, the controller will show the parameter of the preset, users can hold  to exit the skimmer duration each time. When the skimmer duration ends, the pump will return to the normal state for the users to operate.

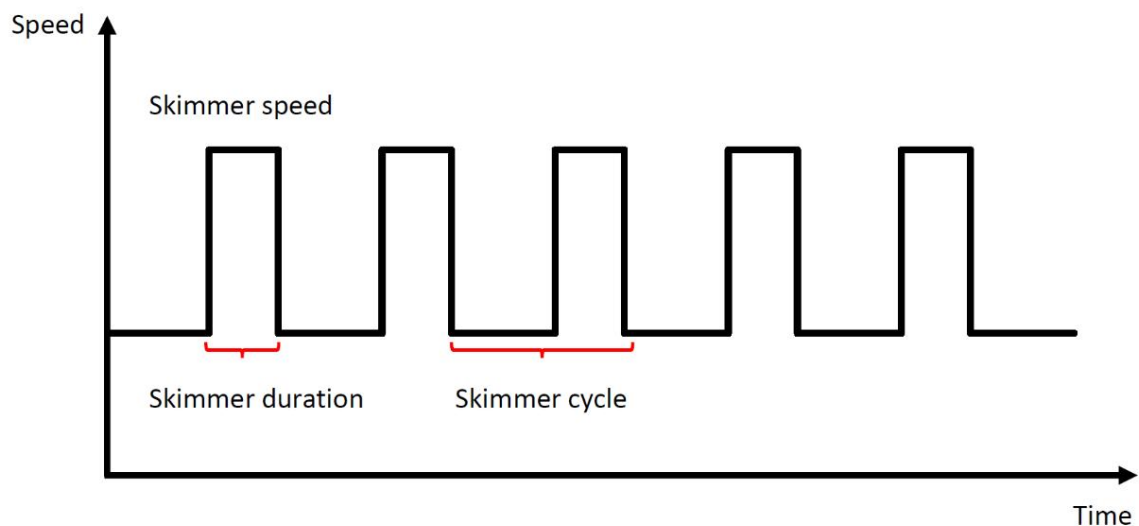
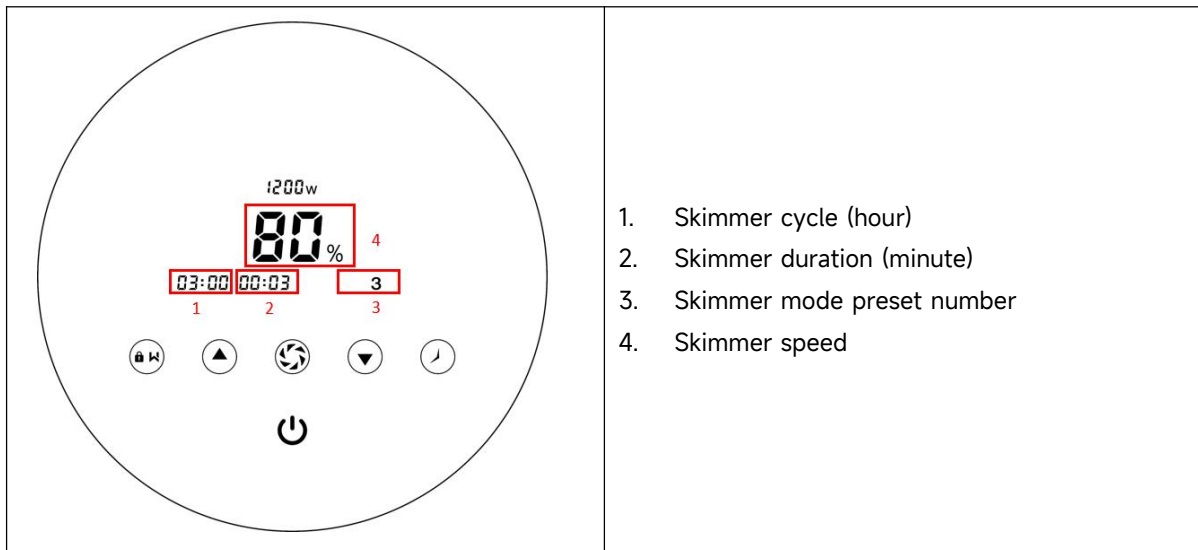

Preset	Skimmer cycle	Skimmer duration	Skimmer speed	Time period	Remark
1	1h	3 min	100%	7:00 – 21:00	Editable in

					parameter setting
2	1h	10 min	100%	7:00 – 21:00	Not editable
3	3h	3 min	80%	7:00 – 21:00	Not editable

5.10. Speed Limit









Users can set the speed limit of the running capacity to meet the flow requirement of other equipment such as sand filters.

Speed limit of the running capacity can be set from 60% - 100% in the parameter setting (see 5.11). 100% means no speed limit and the running capacity can be set from 30% - 120% under normal operation.

To ensure the performance, the following mode or process will not be limited by the speed limit:

1. Self-priming at each start
2. Manual self-priming
3. Self-learning
4. Auto Inverter mode
5. Flow rate setting in the timer mode





5.11. Parameter Setting

Restore factory setting	Under off mode, hold both   for 3 seconds
Check the software version	Under off mode, hold both   for 3 seconds
Enter parameter setting as below	Under off mode, hold both   for 3 seconds; If current address does not need to be adjusted, hold both   or press  to next address

Parameter Address	Description	Default Setting	Setting Range
1	Di2 (Digital input 2)	100%	30-120%, by 5% increments
2	Di3 (Digital input 3)	80%	30-120%, by 5% increments
3	Di4 (Digital input 4)	40%	30-120%, by 5% increments
4	Backwash capacity	100%	80-100%, by 5% increments
5	Control mode of Analog Input	0	0: Current control 1: Voltage control

6	Enable or disable the self-priming at each start	25	25: enables 0: disables
7	Reserved	0	Not editable
8	System time	00:00	00:00 - 23:59
9	Preset 1 of the skimmer mode (skimmer cycle, skimmer duration, skimmer speed)	01:00 00:03 100%	Skimmer cycle: 1-24h, 1h for each step Skimmer duration: 1-30min, 1min for each step Skimmer speed: 30%-100%, by 5% increments
10	Time period of the preset 1 of the skimmer mode	7:00-21:00	Start time: 00:00-24:00 End time: 00:00-24:00
11	Speed limit	100%	60%-100%, by 5% increments 100% means no speed limit
12	RS485 address	170(0xAA)	160-190 (0xA0-0xBF), each step by 1.
13	Time intervals to trigger the self-learning automatically	0	0, 1, 3, 5, 7, 14, 21, 28 (day) "0" means will not trigger the self-learning automatically

For example: How to Enable/Disable Self-Priming Function?

- 1) **Enter parameter setting:** Under off mode, hold both   for 3 seconds;
- 2) **Select parameter address:** Press  to address 6;
- 3) **Enable or disable the self-priming at each start:** Adjust by pressing  or ,
25= Enables, 0=Disables.

6. WIFI OPERATION

① Download InverFlow APP



Android



iOS



② Account Registration

Register by e-mail or third-party application.

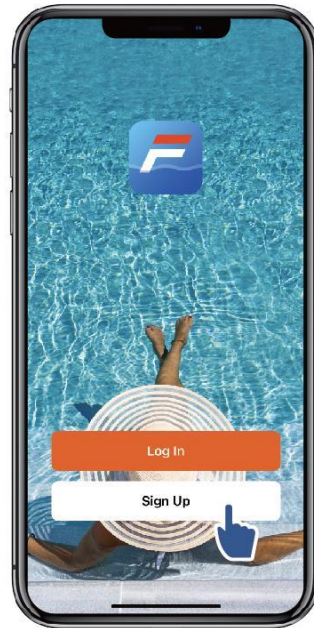

a. Email Registration

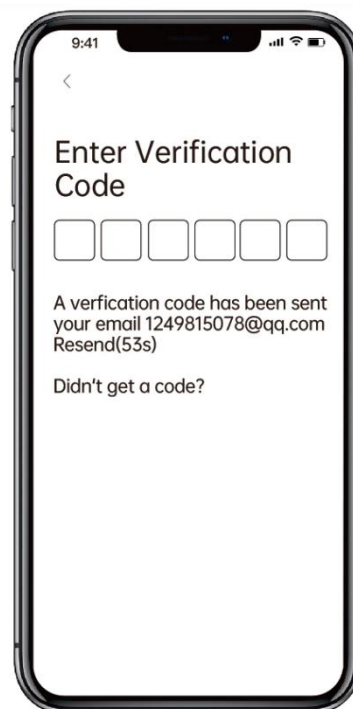
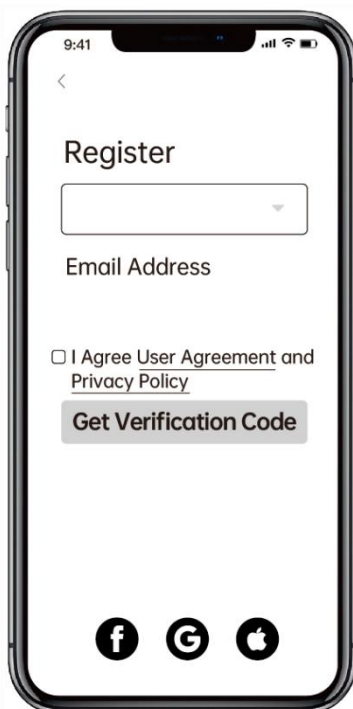

b. Third-party application registration

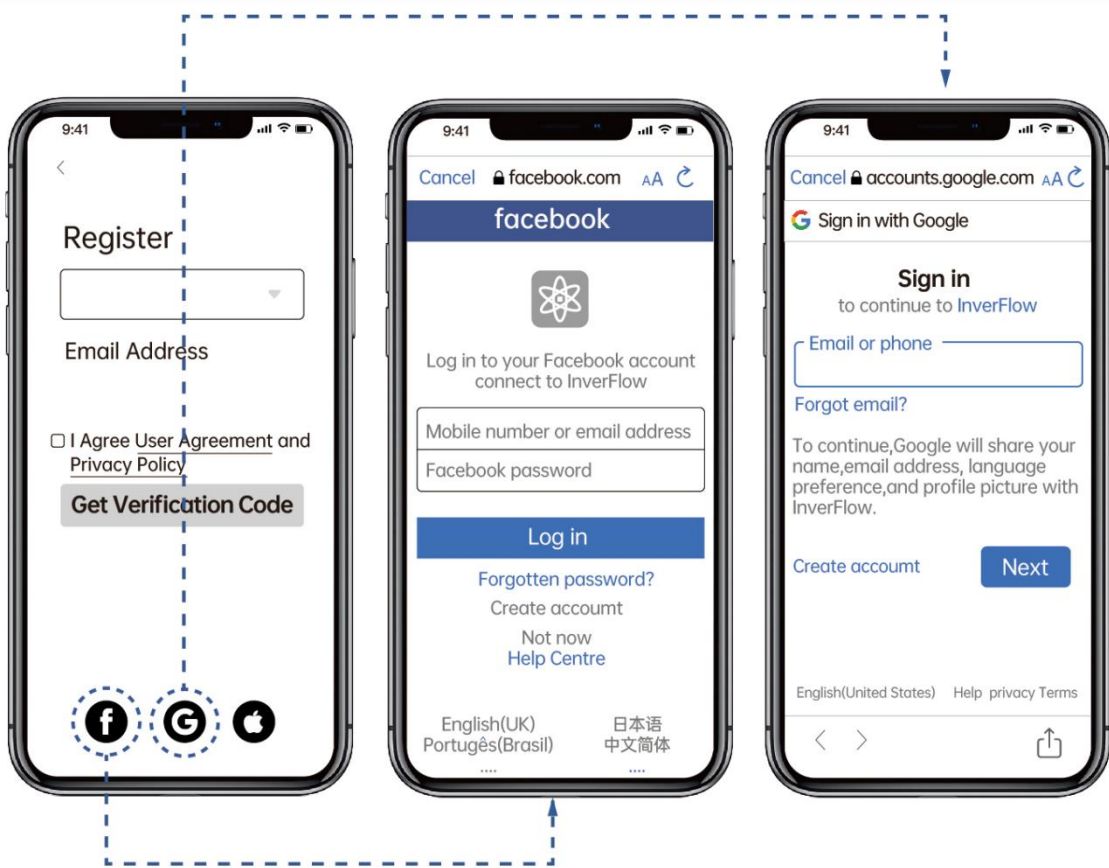

3 Create Home

Please set home name and choose the location of the device. (It is recommended to set the location so the weather can be shown in the App for your convenience)

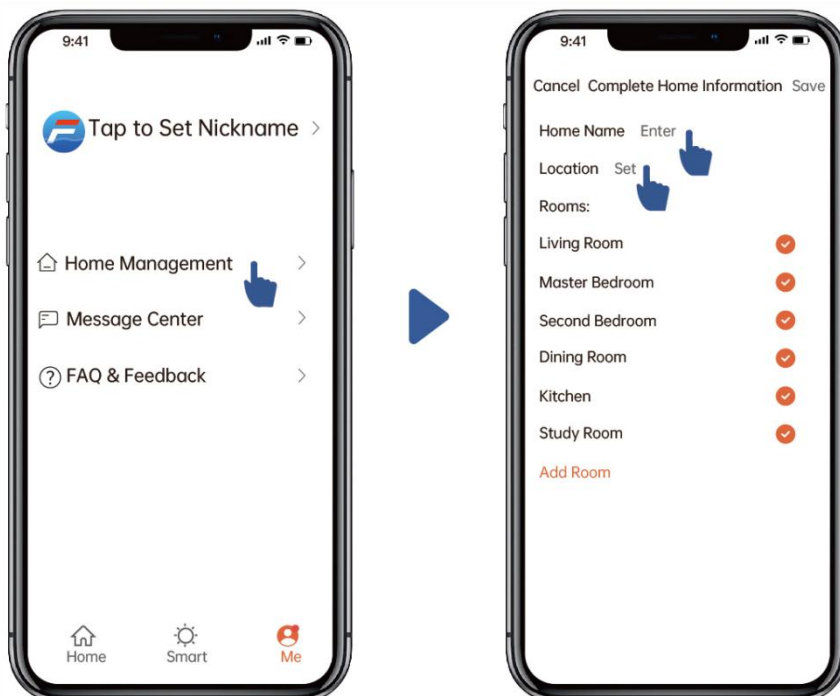

4 App pairing

Please make sure your pump is turned on before you start.

Option 1 (Recommended): With Wifi and Bluetooth

(Network requirement: 2.4GHz; 2.4Ghz and 5GHz into one SSID; but no separate 5GHz network)

1) Please confirm that your phone is connected to Wifi and your Bluetooth is on.

2) Press  for 3 seconds until hearing “Beep” to unlock the screen. Press  for 5

seconds until hearing “Beep” and then release.  will flash.

3) Click “Add Device”, and then follow the instructions to pair device.

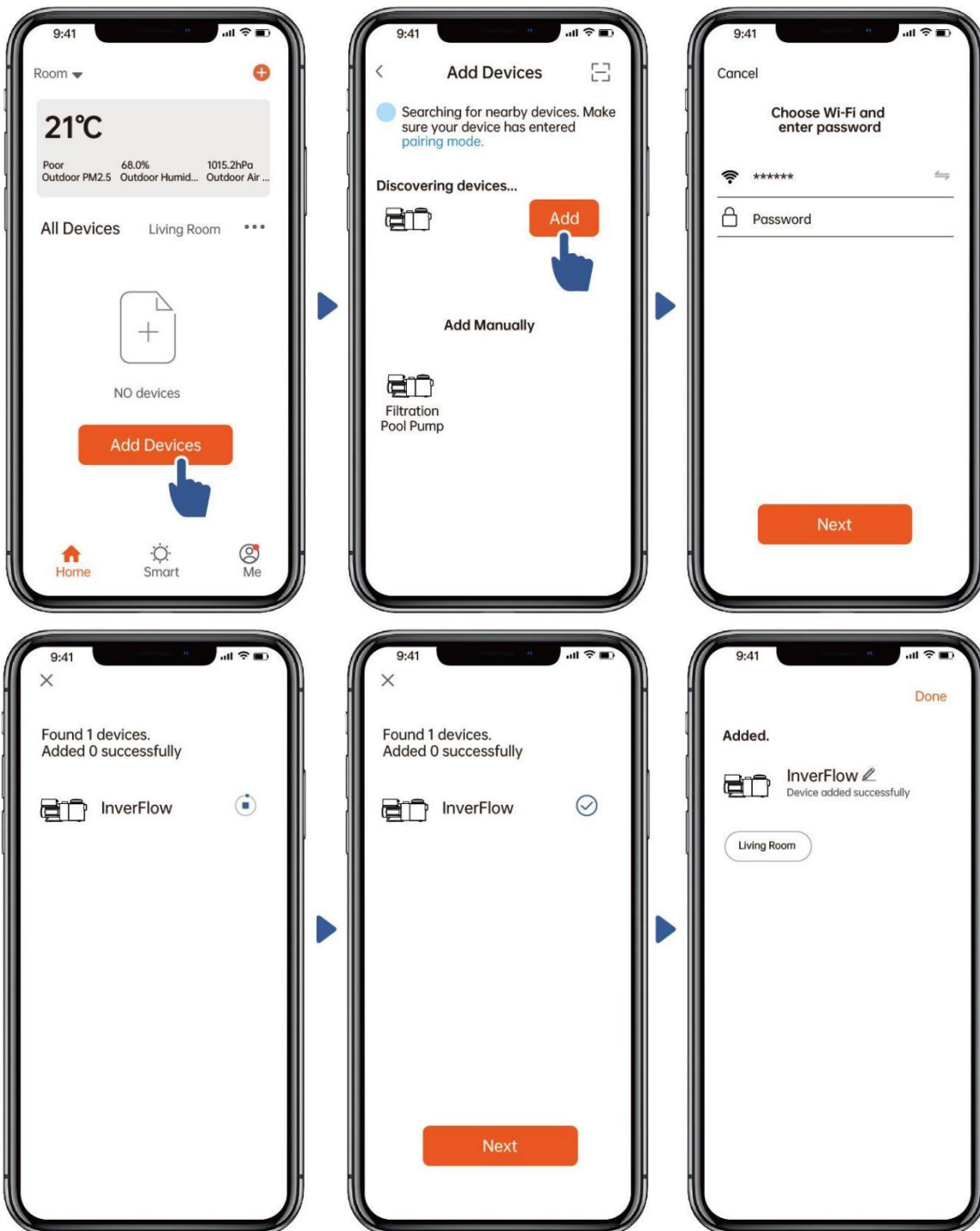

Option 2: With Wifi (Network requirement: 2.4GHz only)

1) Please confirm that your phone is connected to Wifi

2) Press  for 3 seconds until hearing “Beep” to unlock the screen. Press  for 5

seconds until hearing “Beep” and then release.  will flash.

3) Click “Add Device”, and then follow the instructions to pair device.

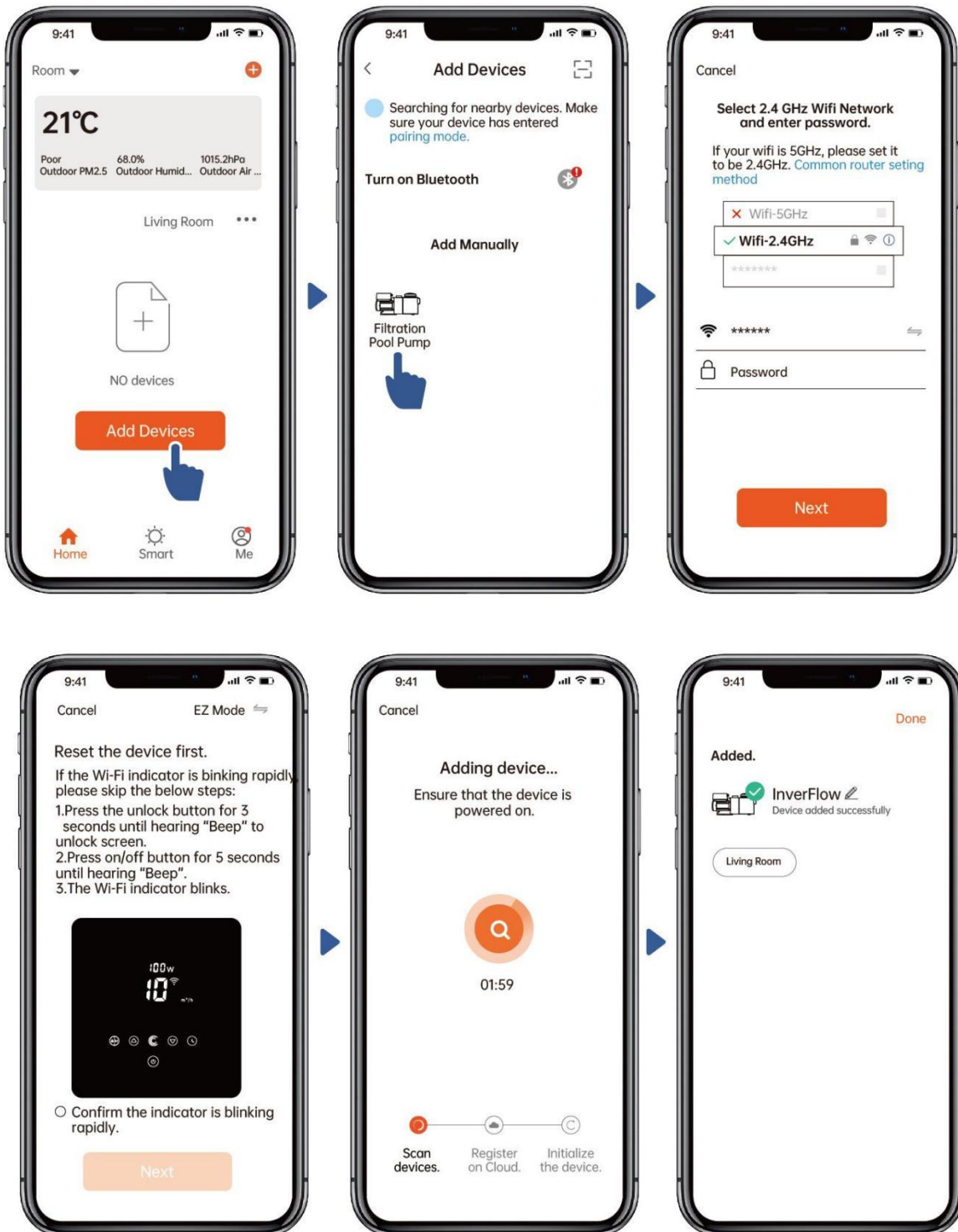

5 Operation

1) Using Auto Inverter mode:

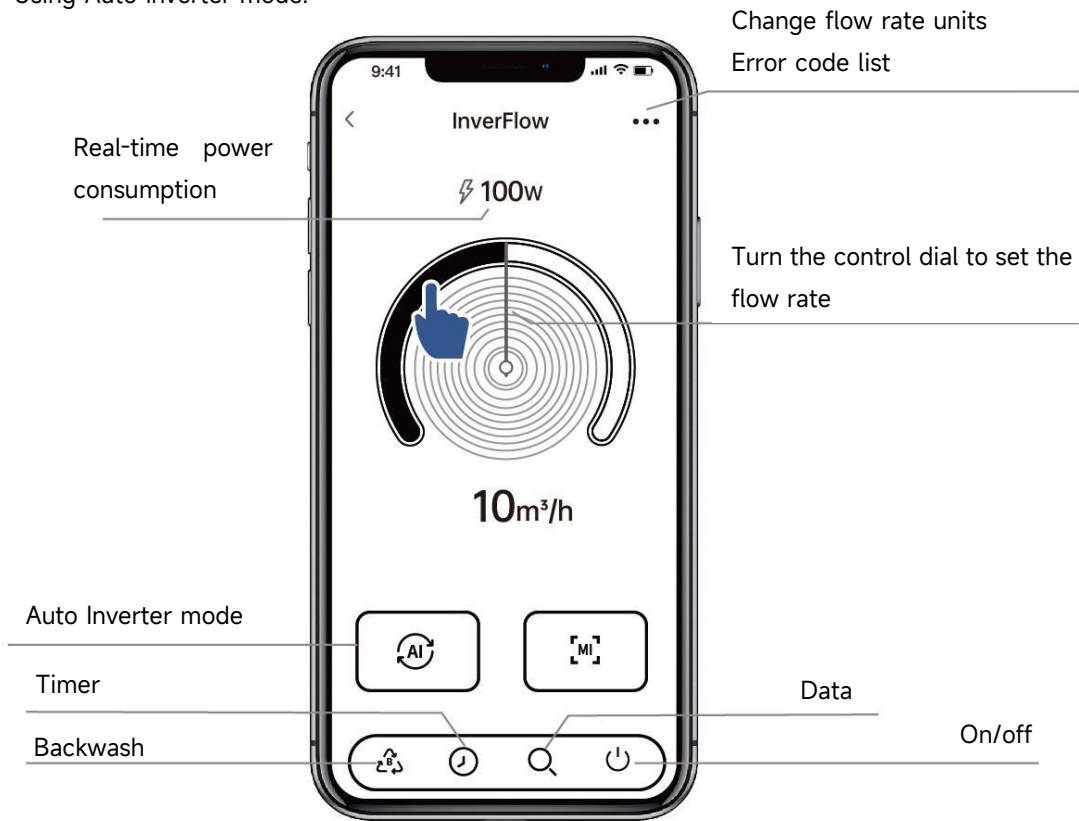

2) Using Manual Inverter mode:

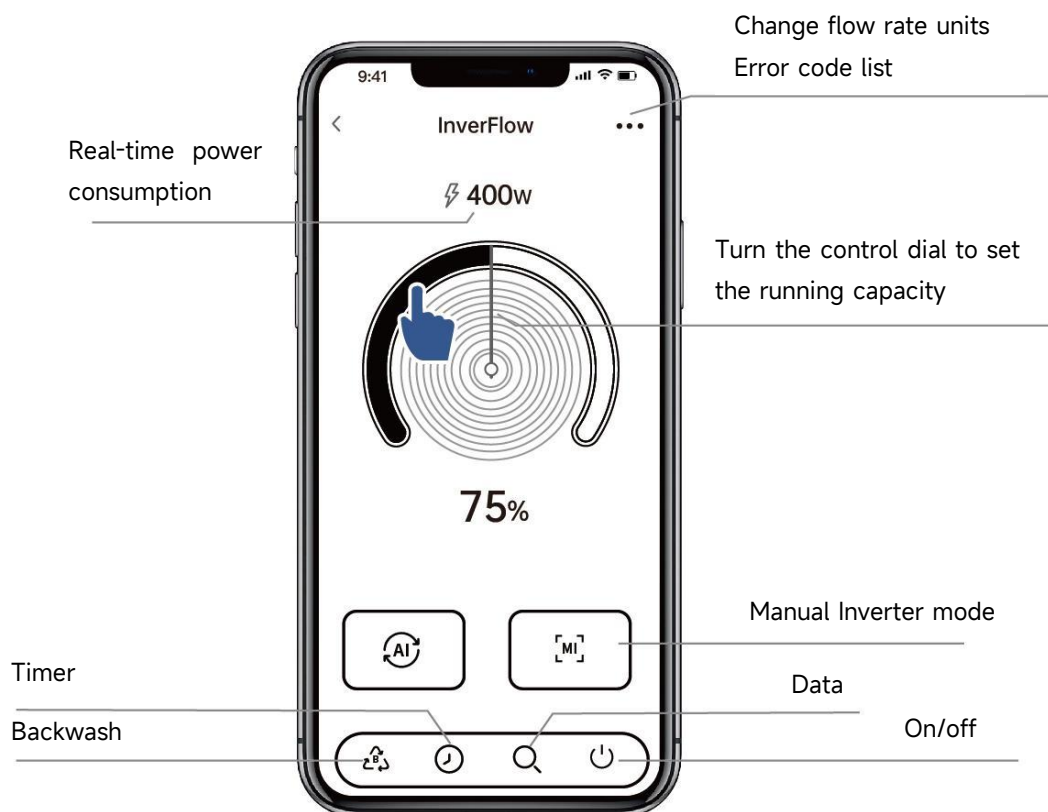

Notice for the timer setting via the APP:

- 1) Time variance is $\pm 30s$;
- 2) In order to avoid overlapping timing points conflicting and invalidating due to network delay, it is recommended that the end time and the start time of the next timing period cannot overlap, and a sufficient time interval should be reserved, for example, at least 2 minutes;

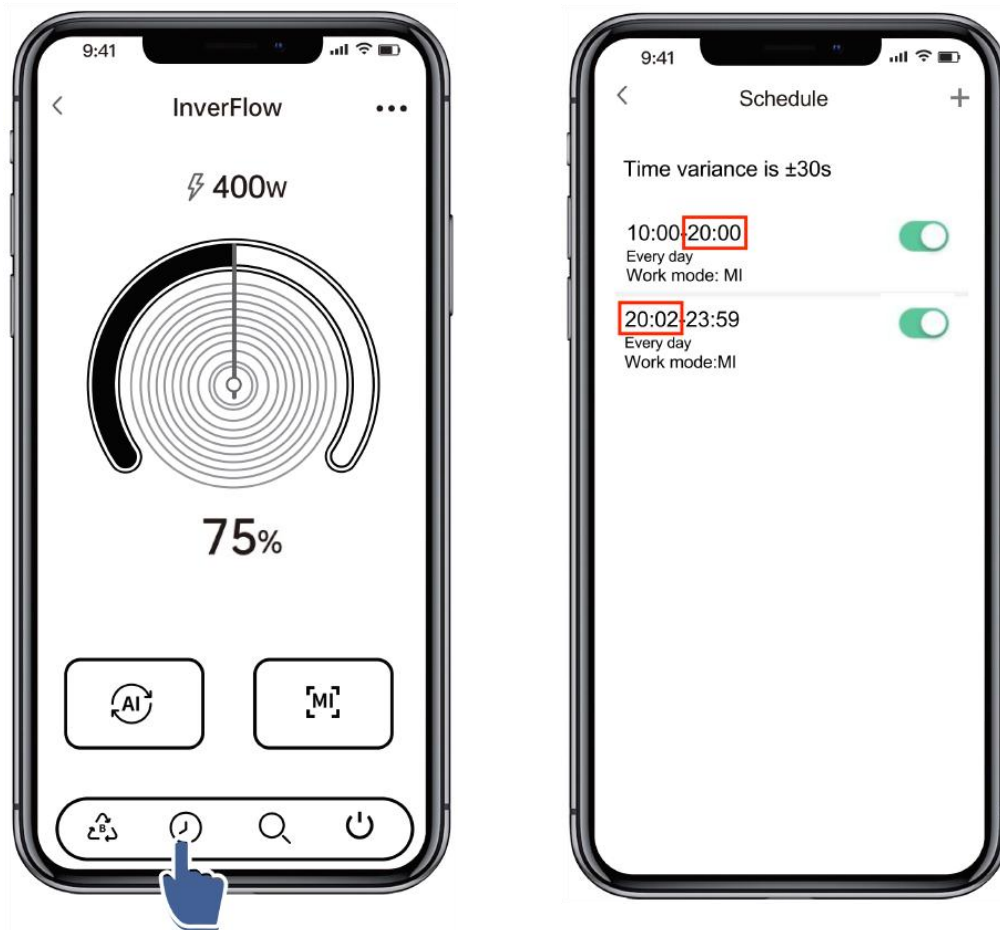

6 Sharing Devices with your family members

After pairing, if your family members also want to control the device, please let your family members register “InverFlow” first, and then the administrator can operate as below:

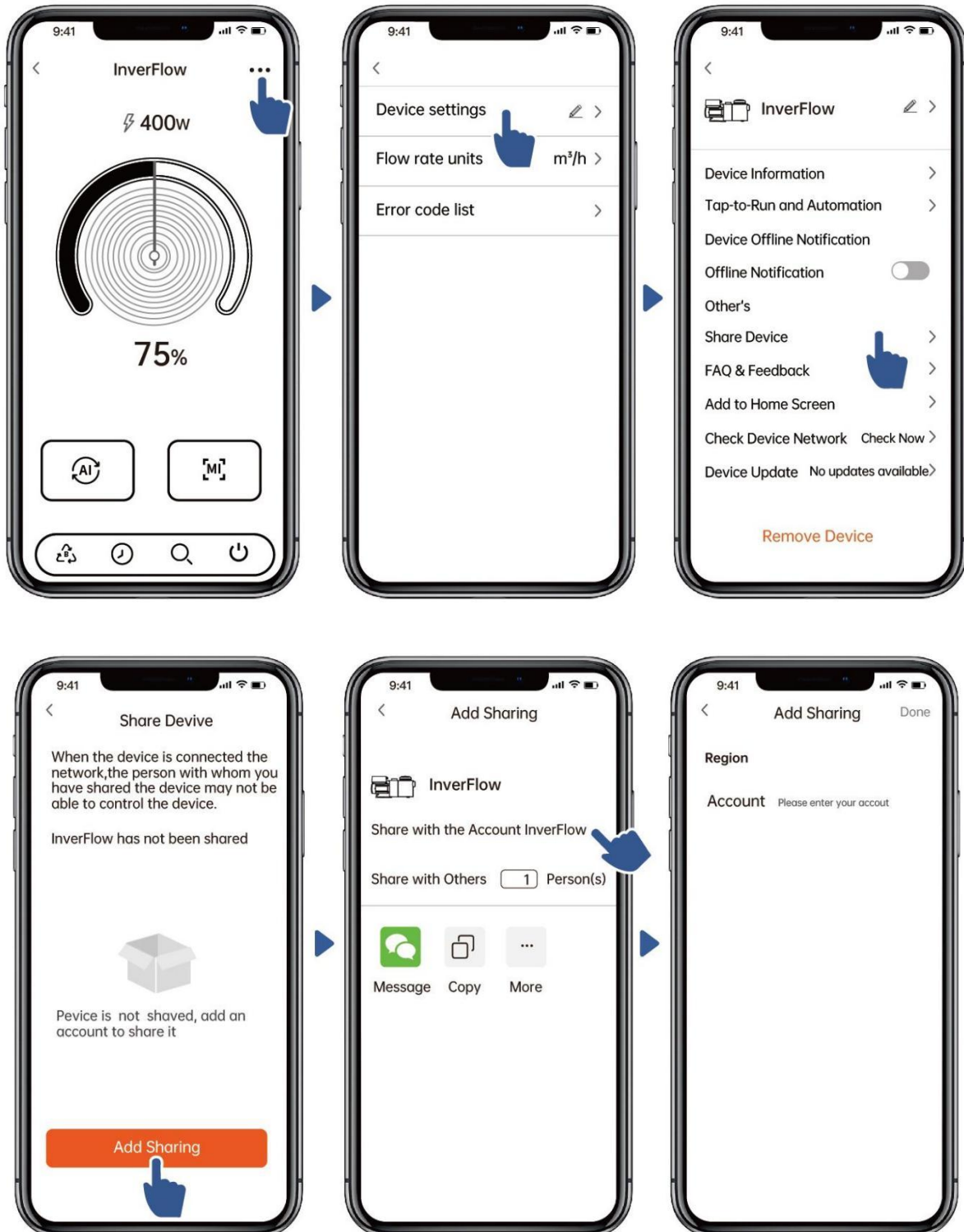

7 Feedback

If you have any problem while using, welcome to send feedback.

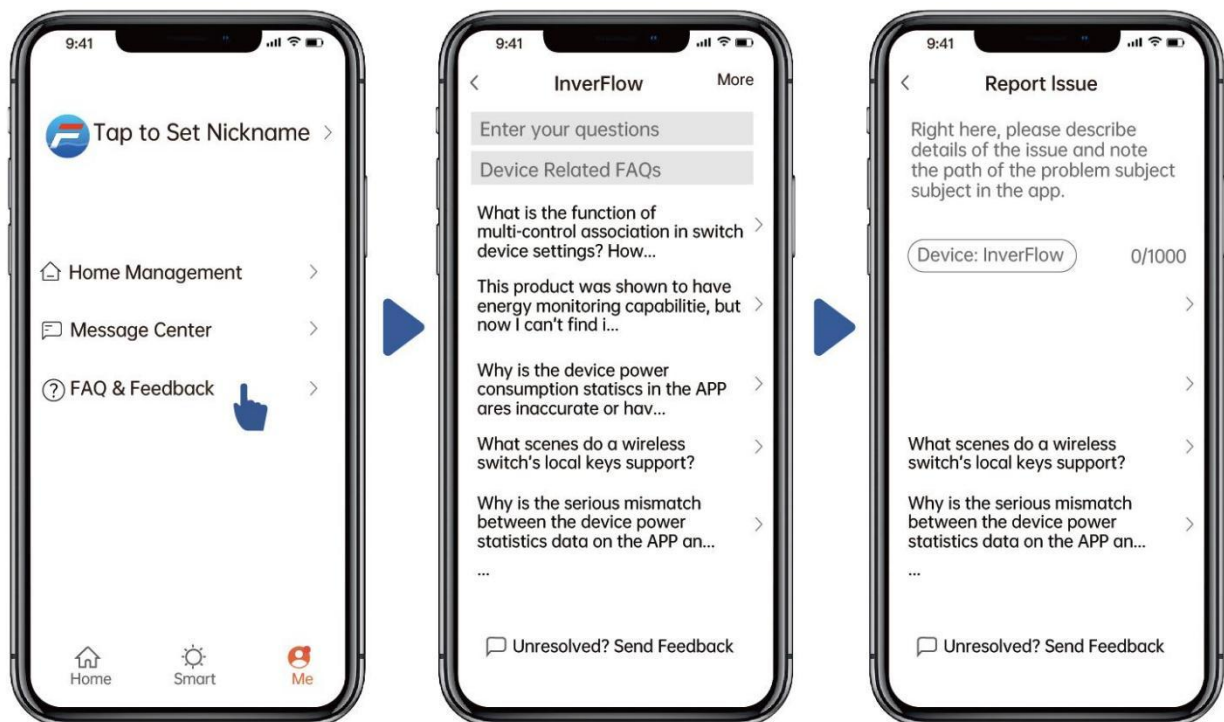

Notice:

- 1) The weather forecast is just for reference;
- 2) The power consumption data is for reference only, as it may be affected by network problems and imprecision of the calculation.
- 3) The App is subject to updates without notice.

7. EXTERNAL CONTROL

External control can be enabled via following contacts. If more than one external control is enabled, the priority is as below: Digital Input > Analog Input > RS485 > Panel control .

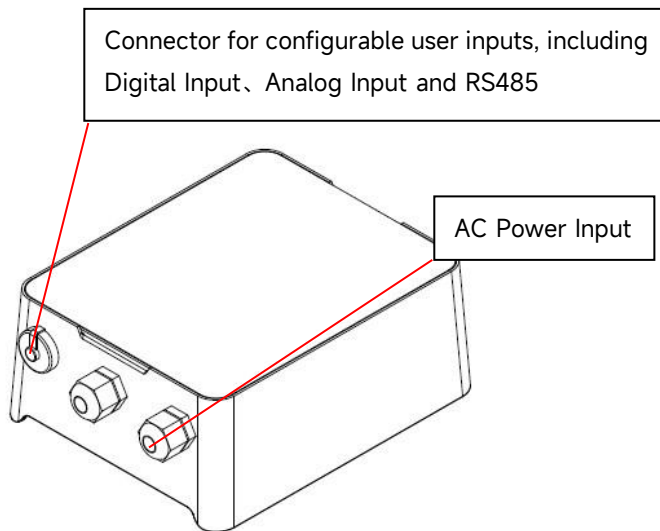

Figure 4 - Connector port location

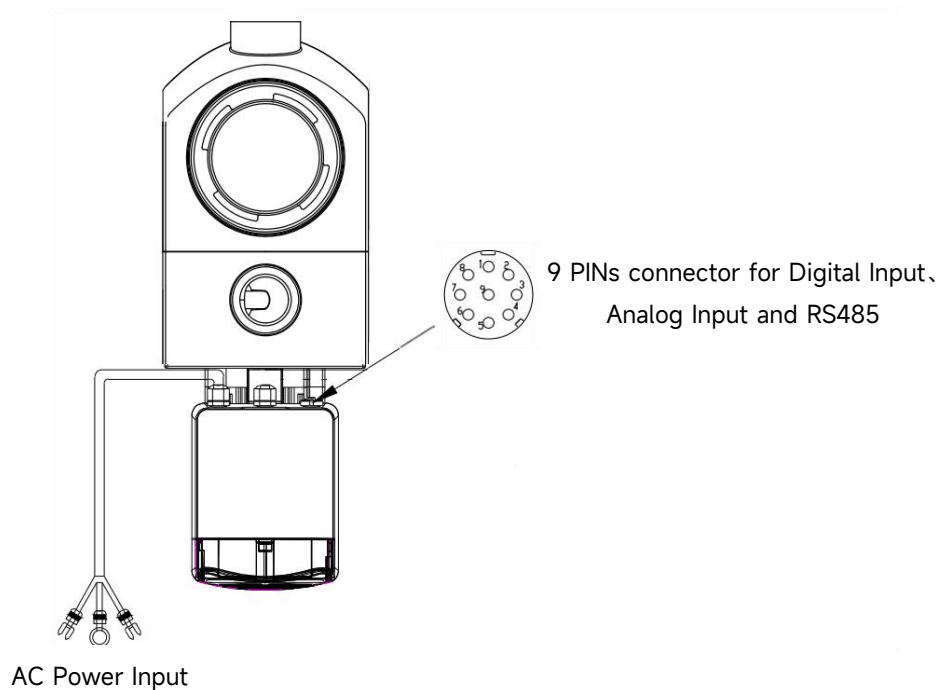

Figure 5 - Digital Input, Analog Input and RS485 connector

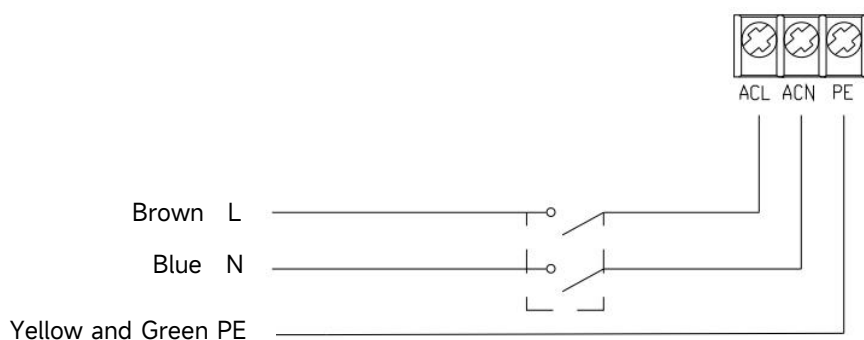

Figure 6 - Power cord connection

External Control	Color	Description
Digital Input	Red	Di4 (Digital Input 4)
	Black	Di3 (Digital Input 3)
	White	Di2 (Digital Input 2)
	Grey	Di1 (Digital Input 1)
	Yellow	Digital Ground (COM)
RS485	Green	RS485-A
	Brown	RS485-B
Analog Input	Blue	Analog Input (0~10V or 0~20mA)
	Orange	Analog Ground

a. Digital Input

Running capacity is determined by the state of digital input,

- 1) When Di1(Grey) connects with COM(Yellow), the pump will be mandatory to stop; if disconnected, the digital control will be invalid;
- 2) When Di2(White) connects with COM(Yellow), the pump will be mandatory to run at 100%; if disconnected, the control priority will be back on panel control;
- 3) When Di3(Black) connects with COM(Yellow), the pump will be mandatory to run at 80%; if disconnected, the control priority will be back on panel control;
- 4) When Di4(Red) connects with COM(Yellow), the pump will be mandatory to run at 40%; if disconnected, the control priority will be back on panel control;
- 5) The capacity of inputs (Di2/Di3/Di4) could be modified according to the parameter setting.

b. RS485

To connect with RS485-A(Green) and RS485-B(Brown), the pump could be controlled via Modbus 485 communication protocol.

c. Analog Input

To connect with Analog Input(Blue) and Analog Ground(Orange), running capacity could be determined by 0~10V analog voltage signal or 0~20mA analog current signal.

State	Current control (mA)	Voltage control (V)
Invalid	0—2.6	0—1.3
Power off	2.6—5.8	1.3—2.9
30%	5.8—6.8	2.9—3.4
35%	6.8—7.6	3.4—3.8
40%	7.6—8.4	3.8—4.2
45%	8.4—9.2	4.2—4.6
50%	9.2—9.8	4.6—4.9
55%	9.8—10.6	4.9—5.3
60%	10.6—11.4	5.3—5.7
65%	11.4—12.0	5.7—6.0
70%	12.0—12.8	6.0—6.4
75%	12.8—13.6	6.4—6.8
80%	13.6—14.4	6.8—7.2
85%	14.4—15.0	7.2—7.5
90%	15.0—15.8	7.5—7.9
95%	15.8—16.6	7.9—8.3
100%	16.6—17.4	8.3—8.7
105%	17.4—18.0	8.7—9.0
110%	18.0—18.8	9.0—9.4
115%	18.8—19.6	9.4—9.8
120%	19.6—20.0	9.8—10.0

8. PROTECTION AND FAILURE

8.1. High-Temperature Warning and Speed Reduction

In "Auto Inverter/Manual Inverter Mode" and "Timer mode" (except backwash/self-priming), when the module temperature reaches the high-temperature warning trigger threshold (81°C), it enters the high temperature warning state; when the temperature drops to the high-temperature warning release threshold (78°C), the high-temperature warning state is released. The display area alternately displays AL01 and running speed or flow.

If AL01 is displayed for the first time, the running capacity will be automatically reduced as below:

- 1) If current operating capacity is higher than 100%, the running capacity will be automatically reduced to 85%;

- 2) If current operating capacity is between 85% and 100%, the running capacity will be automatically reduced by 15%;
- 3) If current operating capacity is between 70% and 85%, the running capacity will be automatically reduced by 10%;
- 4) If current operating capacity is lower than 70%, the running capacity will be automatically reduced by 5%.

8.2. Undervoltage protection

When the device detects that the input voltage is less than 198V, the device will limit the current running speed. The display area alternately displays AL02 and running speed or flow.

- 1) When input voltage is less than or equal to 180V, the running capacity will be limited to 70%;
- 2) When the input voltage range is within 180V - 190V, the running capacity will be limited to 75%;
- 3) When the input voltage range is within 190V - 198V, the running capacity will be limited to 85%.

8.3. Troubleshooting

Problem	Possible causes and solution
Pump does not start	<ul style="list-style-type: none"> • Power Supply fault, disconnected or defective wiring. • Fuses blown or thermal overload open. • Check the rotation of the motor shaft for free movement and lack of obstruction. • Because of a long time lying idle. Unplug the power supply and manually rotate motor's rear shaft a few times with a screwdriver.
Pump does not prime	<ul style="list-style-type: none"> • Empty pump/strainer housing. Make sure the pump/strainer housing is filled with water and the O ring of cover is clean. • Loose connections on the suction side. • Strainer basket or skimmer basket loaded with debris. • Suction side clogged. • Distance between pump inlet and liquid level is higher than 2m, the installation height of pump should be lowered.
Low Water Flow	<ul style="list-style-type: none"> • Pump does not prime. • Air entering suction piping. • Basket full of debris. • Inadequate water level in pool.
Pump being noisy	<ul style="list-style-type: none"> • Air leak in suction piping, cavitation caused by restricted or undersized suction line or leak at any joint, low water level in pool, and unrestricted discharge return lines. • Vibration caused by improper installation, etc. • Damaged motor bearing or impeller (need to contact the supplier for repair).

8.4. Error code

When the device detects a failure, it will stop automatically and display the error code. After stopping for 15 seconds, check if the failure is cleared. If cleared, the pump will resume working.

Item	Error Code	Details	
1	E001	Description	Abnormal input voltage: the power supply voltage is out of the range of 165V to 275V.
		Process	The pump will stop automatically for 15 sec and resume working if it detects the power supply voltage is within the range.
2	E002	Description	Output over current: The peak current of the pump is higher than the protection current.
		Process	The pump will stop automatically for 15 sec and then resume working, if this occurs for thrice continuously, the pump will shut down and need to be checked and restarted manually.
3	E101	Description	Heat sink overheat: The heat sink temperature reaches 91°C for 10sec.
		Process	The pump will stop automatically for 30 sec and resume working if it detects the heat sink temperature is less than 81°C.
4	E102	Description	Heat sink sensor error: The heat sink sensor detects an open or short circuit.
		Process	The pump will stop automatically for 15 sec and resume working if it detects the heat sink sensor is not open or short circuit.
5	E103	Description	Master driver board error: The Master driver board is faulty.
		Process	The pump will stop automatically for 15 sec and then resume working, if this occurs for thrice continuously, the pump will shut down and need to be checked and restarted manually.
6	E104	Description	Phase-deficient protection: Motor cables are not plugged into the master drive board.
		Process	The pump will stop automatically for 15 sec and then resume working, if this occurs for thrice continuously, the pump will shut down and need to be checked and restarted manually.
7	E105	Description	AC current sampling circuit failure: When the pump power off, the bias voltage of the sampling circuit is out of the range of 2.4V~2.6V.
		Process	The pump needs to be powered off and restarted manually.
8	E106	Description	DC abnormal voltage: The DC voltage is out of the range of 210V to 420V.

		Process	The pump will stop automatically for 15 sec and then resume working, if this occurs for thrice continuously, the pump will shut down and need to be checked and restarted manually.
9	E107	Description	PFC protection: PFC protection occurs on the Master driver board.
		Process	The pump will stop automatically for 15 sec and then resume working, if this occurs for thrice continuously, the pump will shut down and need to be checked and restarted manually.
10	E108	Description	Motor power overload: Motor power exceeds the rated power by 1.2 times
		Process	The pump will stop automatically for 15 sec and then resume working, if this occurs for thrice continuously, the pump will shut down and need to be checked and restarted manually.
11	E201	Description	Circuit board error: When the pump power off, the bias voltage of the sampling circuit is out of the range of 2.4V~2.6V.
		Process	The pump needs to be powered off and restarted manually.
12	E203	Description	RTC time reading error: Reading and writing the information of timer clock is incorrect.
		Process	The pump needs to be powered off and restarted manually.
13	E204	Description	Display Board EEPROM reading failure: Reading and writing the information of display board EEPROM is incorrect.
		Process	The pump needs to be powered off and restarted manually.
14	E205	Description	Communication Error: The communication between display board and master driver board is failure lasts 15 sec.
		Process	The pump will stop automatically for 15 sec and resume working if it detects the communication between display board and master driver board lasts 1 sec.
15	E207	Description	No water protection: The pump is lack of water.
		Process	Stop the pump manually, fill up the pump with water and restart it. If this occurs for twice continuously, the pump will shut down and need to be checked manually.
16	E209	Description	Loss of prime: The pump cannot self-priming due to the reasons such as exceeding the suction range or the pipeline is too complicated.
		Process	Check the pump or pipeline that there is no leakage, and then fill up the pump with water and restart it.

9. MAINTENANCE

Empty the strainer basket frequently. The basket should be inspected through the transparent lid and emptied when there is an evident stack of rubbish inside. The following instructions should be followed:

- 1). Disconnected the power supply.
- 2). Unscrew the strainer basket lid anti-clockwise and remove.
- 3). Lift up the strainer basket.
- 4). Empty the trapped refuse from the basket and rinse out the debris if necessary.

Note: Do not knock the plastic basket on a hard surface as it will cause damage

- 5). Inspect the basket for signs of damage, and replace it.
- 6). Check the lid O-ring for stretching, tears, cracks or any other damage
- 7). Replace the lid, hand tightening is sufficient.

Note: Periodically inspecting and cleaning the strainer basket will help prolong its life.

10. WARRANTY & EXCLUSIONS

Should a defect become evident during the term of warranty, at its option, the manufacturer will repair or replace such item or part at its own cost and expense. Customers need to follow the warranty claim procedure in order to obtain the benefit of this warranty.

The guarantee will be void in cases of improper installation, improper operation, inappropriate use, tampering or using of non-original spare parts.

11. DISPOSAL



When disposing of the product, please sort the waste products as electrical or electronic product waste or hand it over to the local waste collection system.

The separate collection and recycling of waste equipment at the time of disposal will help ensure that it is recycled in a manner that protects human health and the environment.

Contact your local authority for information on where you can drop off your water pump for recycling.

